

MODULATED CAPILLARY TITRATION CALORIMETER Theoretical and experimental studies

G. V. Kotelnikov*, S. P. Moiseyeva and E. V. Mezhiburd

Institute for Biological Instrumentation, Russian Academy of Sciences, 142290 Pushchino, Moscow Region, Russia

A modulated capillary titration calorimeter has been developed. New software and optimization of the calorimetric unit CTD2156 are used as a basis of the modulated capillary titration calorimeter. The scanning mode of the calorimeter has been theoretically substantiated. The scanning of chambers temperature is provided due to the fact that the shield temperature is linearly varied at heating and cooling. The reversing and kinetic part of the total heat flow are measured at heating of a diluted collagen solution. The main advantage of the calorimeter is its ability to operate in a modulation mode, in an isothermal mode, in modes of linear heating and cooling of homogeneous and dispersoid liquid samples at an effective mixing of reagents in calorimetric chambers.

Keywords: capillary titration calorimeter, kinetic heat flow, reversing heat flow, StepScan DSC, TMDSC

Introduction

For the last years the titration calorimetry has become a ‘gold standard’ in the description of biomolecular interactions and stability. It is used for obtaining rigorous and complete information on the molecular mechanism of binding and stability for a wide number of biomolecules, for identification and definition of the biological role of new biomolecules, as there is an increasing need for the description of these biomolecules by a high resolution method, such as calorimetry. The titration microcalorimetry has a potential to become a leading technology in drug design, because it provides more complete and rigorous thermodynamic characterization of a binding process, namely the number of binding sites n (reaction stoichiometry); the binding affinity constant (K), expressing the force of binding and defining the free energy (ΔG), where $\Delta G = RT \ln K$; the contribution of enthalpy (ΔH) and of entropy (ΔS) to the free energy, where $\Delta G = \Delta H - T\Delta S$ [1].

However, modern titration calorimeters work only in an isothermal mode. This instrument does not allow obtaining a complete thermodynamic description of the native state of biomolecules and their transient states, which appear upon temperature scanning.

At present the mentioned above problems are solved with the help of highly sensitive scanning microcalorimeters. Main researches of proteins and peptides, membrane and protein–membrane systems, nucleic acids, polysaccharides, cells and tissues and synthetic polymers [2] have been accomplished with the adiabatic scanning calorimetry method. In adiabatic scanning cal-

orimeters complex thermostating systems containing inertial objects are used. Traditionally used control systems in these instruments do not provide a required fast response for the modulation mode. Therefore till the modulation measurement method in adiabatic scanning calorimeters has not been used so far. With an adiabatic scanning calorimeter DACM-4, designed for studying diluted protein solutions, investigations of granulose starch heated at an excess of water are performed and the enthalpy of the thermal process without selection of kinetic and reversing components is obtained [8, 9]. Researches of aqueous starch dispersion [3–5] are actively carried out with TMDSC method. Such studies carried out on modulation calorimeters, have allowed selecting the reversing and kinetic components from the registered signal [8].

The modulated temperature DSC technique (TMDSC) has been developed since the 90-ies [9]. This method is realized in the Diamond Differential Scanning Calorimeter (PerkinElmer, Inc., USA), the DSC822 e Mettler Toledo instrument (Switzerland) and a number of other dynamic scanning calorimeters (Q1000, Q100 etc. corporation TA Instruments, USA). The TMDSC technique was protected by patents EP0803061, US5224775 and number of other patents. The TMDSC’s calorimetric chambers have high dynamic performances, that provide a fast response of these instruments in no more than several seconds. The TMDSC allows to study very small heat effects such as, for example, the glass transition process in a thin polymer film at scanning rates up to ten degrees per minute. However, the TMDSC is not ap-

* Author for correspondence: gvkotelnikov@rambler.ru

plied to study dilute protein solutions, as aqueous protein solutions are analyzed at low scanning rates, when the maximal rate does not exceed several degrees per minute, and at such a rate the DSC sensitivity is insufficient for the measured heat flow.

Thus, despite of obvious advantages of the modern scanning and titration microcalorimeters, they do not meet the requirements of the up-to-date the researches.

The experimental and theoretical studies done at the Institute for Biological Instrumentation, Russian Academy of Sciences, to develop a capillary titration calorimeter have resulted in the creation of a modulation capillary scanning titration calorimeter, which is a good tool for comprehensive measurements of diluted protein solutions.

Brief description of the capillary titration calorimeter

New software and optimization of the calorimetric unit CTD2156 are used as a basis of the modulated capillary titration calorimeter with a temperature scanning mode and a modulation mode. The capillary differential titration calorimeter CTD2156 was described in our previous papers [10–12].

The capillary titration calorimeter comprises a calorimetric unit, a titration unit, an electronic unit, a nanovoltmeter HP34420A, a computer with two boards Lab-PC+ and a board PC-TIO-10 (all boards are from the National Instruments, USA). The calorimetric unit comprises two calorimetric cells designed as capillary tubes. To separate the sensitive volume, an active and a passive heat-conducting bridges are used. The heat-conducting bridge 1 is designed to separate the sensitive volume of calorimetric cells. The heat exchange with the environment through the outlet part of the capillary tubes is prevented by the heat-conducting bridge 2.

Figure 1 shows a schematic representation of the calorimetric unit. The main elements of the thermostatic control in the calorimetric cells are a constant-temperature shield and a thermopile-based thermostat. The housing of the instrument represents the load-carrying structure bearing a calorimetric unit and a titration unit. The titration unit consists of two syringes located in a common case. The pistons of the dispensing syringes are joined together by means of a connecting bar. To perform the titrant injection process in the calorimetric cells, the case of the syringes is tied to a first screw mechanism, the bar being tied to a second screw mechanism. The screw mechanisms are actuated by stepping motors. The high stability of experimental data received on the calorimeter confirms high efficiency of the mode of the injecting

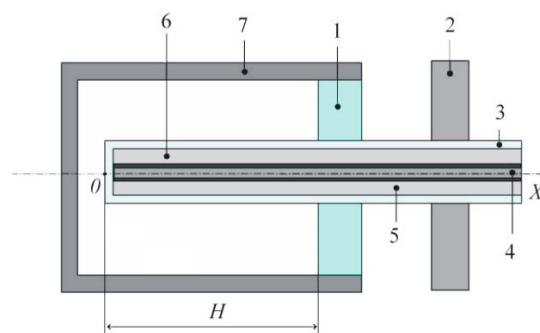

Fig. 1 Calorimetric unit ensuring the modulation mode and the mode of introducing an injecting needle into the calorimetric chamber through the active bridge: 1 – bridge 1 (passive), 2 – bridge 2 (active), 3 – chamber, 4 – needle with titrant, 5 – sample, 6 – reaction area, 7 – shield, H – calorimetric chamber length

needle moving into the calorimetric chamber through the active bridge.

This allows operating with homogeneous liquid samples and dispersoid samples giving a sediment, as well as operating with reagents prepared on organic solvent. The oscillating dosing needle enters camera up to the bottom, which prevents sedimentation of dispersoid sample. The oscillating dosing needle is drawn from the chamber in a titration mode, which prevents the organic dissolvent ingress in the sensitive volume of calorimetric chambers at studying biochemical reactions through the needle end during prolonged measurement. Thus, the measurement precision is improved due to elimination of the organic solvent interaction with the sample in the calorimetric chamber.

The CTD2156's calorimetric unit, represented in Fig. 1, allows to vary dynamic characteristics of the measuring and control systems of the calorimeter over a wide range by using modern automation resources. So the capillary titration calorimeter operating in the modulation mode with required modulation parameters depending on the experiment task has been developed.

Temperature scanning mode in the modulation capillary differential titration calorimeter

The chambers temperature scanning is provided due to linear variation of shield temperature at heating and cooling (Eq. (1))

$$T_{\text{sh}} = T_0 + \nu\tau \quad (1)$$

where T_{sh} is the current shield temperature; T_0 is the initial shield temperature at $\tau=0$; ν is the linear heating rate, and τ is the current time.

The heating power of the calorimetric chamber having the length H at the linear shield heating rate ν

is determined by a heat input to the chamber in the place of the chamber contact with a bridge and by a heat exchange with the environment (Fig. 1). In doing so the chamber temperature in any point of its length and the cut, and also the temperature of the environment enclosing the chamber, are varied with rate ν . The mode is quasistationary, as the temperature gradient field is stationary [13].

The temperature difference along the chamber radius is practically absent due to intensive mixing of the reagents in the chamber. The temperature distribution along the chamber length is determined according to [15] by the following expression in a steady-state mode:

$$\frac{T(x,\tau)-T_0}{T_0} = Pd \left[F_0 - \frac{1}{2} \left(1 - \frac{x^2}{H^2} \right) \right] \quad (2)$$

where $F_0 = \alpha\nu/H^2$ is Fourier's criterion; $Pd = \nu H^2 / aT_0$ is Predvoditelev's criterion; a is the temperature conductivity coefficient; T_0 is the initial temperature at $\tau=0$; H is the chamber length; x is the current coordinate on the chamber length; τ is the current time and ν is the linear heating rate.

After transformations the temperature expression along the chamber length is obtained:

$$T(x,\tau) = T_0 + \nu\tau - \frac{\nu(H^2 - x^2)}{2a} \quad (3)$$

Thus, the maximal temperature difference along the chamber length is

$$\Delta T(0,\tau) = (T_0 + \nu\tau) - T(0,\tau) = \frac{\nu H^2}{2a} \quad (4)$$

So the temperature difference along the chamber length is equal to 0.033 K for the gold chamber ($a = 124 \cdot 10^{-6} \text{ m}^2 \text{ s}^{-1}$) at the heating rate $\nu = 0.2 \text{ K min}^{-1}$ and the chamber length $H = 5 \cdot 10^{-2} \text{ m}$ and has no practical influence on the temperature measurement result, as it is within in the sample temperature measurement error limit of about 0.1 K.

Consequently the linear temperature scanning mode at the rate from 0 to 0.2 K min^{-1} is provided by the MCTD possibilities to measure the thermal processes power corresponding to those of adiabatic scanning calorimeters operating at the maximal scanning rates from 1 to 2 K min^{-1} . The modulation mode is provided by the assignment of the temperature scanning interval and the isothermal mode interval, which are cyclically replicated in the given temperature range and scanning rates. A detailed description of the MCTD modulation mode will be represented in the patent protecting the technical solution, realized in the given calorimeter.

Measurements of the reversing and kinetic part of the total heat flow at heating of a diluted collagen solution

Chemicals

Collagen was delivered as a 1.9% acid solution from Belkosin Ltd. (Luga, Russia). It was diluted by 0.1 M acetic acid down to concentration 1 mg mL^{-1} for calorimetric measurements.

Measurements of a diluted collagen solution with MCTD

The measurements were carried out with the MCTD. In doing so the temperature program consists of a sequence of heating interval followed by an isothermal interval which are repeated a selected number of time. The reversing part of the total heat flow was determined on the heat flow at the heating interval and its kinetic part on the heat flow at the isothermal interval respectively. This measurement method has been used with PerkinElmer Corporation (USA) in Diamond DSC and it is named StepScan DSC [14, 15].

At measurements the sample chamber was filled by 156 μL of a collagen solution and the reference chamber by 156 μL of 0.1 M acetic acid, pH 3.0. The scanning mode time was 4.5 min at the scanning rate of 0.44 K min^{-1} . The isothermal mode time was 1.5 min. The temperature range was from 23 to 44.2°C .

The data (Fig. 2) were obtained on the MCTD using the StepScan DSC method [14, 15] which was also used to treat the equation $dQ/dt = C_p dT/dt + f(t, T)$. Curve C is the response of the differential heat flow signal dQ/dt to the heating rate (dT/dt) . Curve B represents $C_p dT/dt$ where C_p is the sample heat capacity.

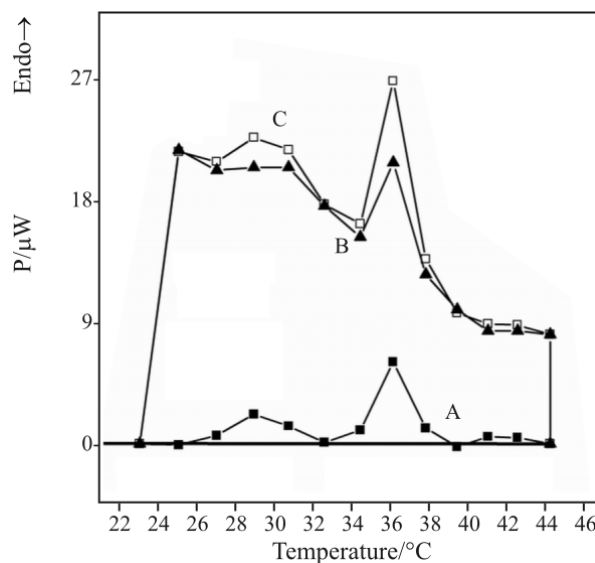

Fig. 2 Curve of the C – total heat flow, A – separated kinetic and B – reversing parts obtained with MCTD using a collagen sample

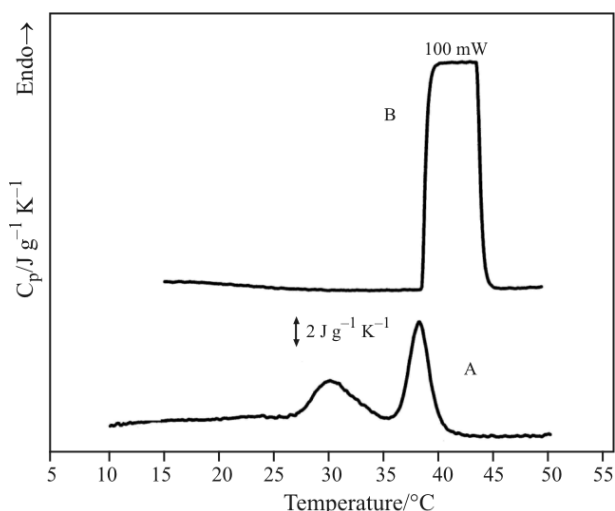

Fig. 3 Curve of the total heat flow obtained with DASM-4 using a collagen sample (curve A). Curve B presents the calibration experiment using electrical power 100 μ W

Curve A shows $f(t, T)$ and represents the heat flow associated with kinetically limited processes due to physical or chemical changes in the sample. Apparently curve A represents a dynamic equilibrium of protein molecules at conformational changes in isothermal conditions.

For the given collagen sample of 1 mg mL⁻¹ concentration the thermogram was also obtained with the adiabatic scanning calorimeter DASM-4 in the linear scanning mode at the linear scanning rate of 1 K min⁻¹ in the temperature range 10–50°C (Fig. 3).

The total heat flow signal representing the sum of the kinetic and reversing parts recorded with the MCTD (Fig. 2) repeats the signal of the collagen denaturation (curve A: Fig. 3) obtained with the DASM-4 (Fig. 3). Thus the representation of the signal recorded at continuous temperature scanning as the sample heat capacity change gives an essential error in estimation of the sample heat capacity change.

Conclusions

For the first time a modulation capillary titration calorimeter has been developed, which provides a possibility to measure the reversing and kinetic parts of the total heat flow, that makes allow obtaining a precise thermodynamic description of the investigated systems.

The MCTD provides operation in an isothermal mode, in modes of linear heating and linear cooling with homogeneous and dispersoid diluted liquid samples at effective reagent mixing in calorimetric chambers. This meets the current research level in biology, biotechnology, biochemistry and medicine.

Acknowledgements

This research was supported by the Russian Foundation for Basic Researches (grant 06-08-01237a).

References

- 1 T. Wiseman, S. Williston, J. F. Brandts and L.-N. Lin, *Anal. Biochem.*, 179 (1989) 131.
- 2 E. Freire, *Methods Enzymol.*, 256 (1995) 144.
- 3 S. N. Moorthy, L. Andersson, A. C. Eliasson, S. Santacruz and J. Ruales, *Starch/Stärke*, 58 (2006) 209.
- 4 P. D. Meuter, J. Amelrijckx, H. Rahier and B. V. Mele, *J. Polym. Sci. Part B: Polym. Phys.*, 37 (1999) 2881.
- 5 I. Tan, C. C. Wee, P. A. Sopade and P. J. Halley, *Starch/Stärke*, 56 (2004) 6.
- 6 S. S. Kozlov, A. V. Krivandin, O. V. Shatalova, T. Noda, E. Bertoft, J. Fornal and V. P. Yuryev, *J. Therm. Anal. Cal.*, 87 (2007) 575.
- 7 S. S. Kozlov, T. Noda, E. Bertoft and V. P. Yuryev, *J. Therm. Anal. Cal.*, 86 (2006) 291.
- 8 Y. Liu and Y. C. Shi, *Starch/Stärke*, 58 (2006) 433.
- 9 M. Reading, *Trends Polym. Sci.*, 1 (1993) 248.
- 10 G. V. Kotelnikov, S. P. Moiseyeva, E. V. Mezhiburd and V. P. Krayev, *J. Therm. Anal. Cal.*, 62 (2000) 39.
- 11 G. V. Kotelnikov, S. P. Moiseyeva, E. V. Mezhiburd and V. P. Krayev, *J. Therm. Anal. Cal.*, 68 (2002) 803.
- 12 G. V. Kotelnikov, S. P. Moiseyeva, E. V. Mezhiburd, E. I. Maevsky and E. V. Grishina, *J. Therm. Anal. Cal.*, 81 (2005) 255.
- 13 A. V. Lykov, *Theory of Heat Conduction*. Moscow, Vysshaya Shkola, 1967, pp. 274–277 (in Russian).
- 14 J. Schawe and M. Margulies, Apparatus and method for differential analysis using real and imaginary signal components, European Patent EP 0 803 061, *Int. Cl.⁷:G01N 25/00* p. 23.
- 15 J. Holubova, Z. Cernosek and E. Cernoskova, *J. Optoelectr. Advanced Mater.*, 7 (2005) 2671.

Received: September 18, 2007

Accepted: December 18, 2007

DOI: 10.1007/s10973-007-8718-z